

EXPANSION JOINTS – Small Movements

GRANOR® Ausflex Compression Seals Series “EF”, “GC” & “WF”



GC 250



EF-SERIES-TYP.



GC 300



WF 400

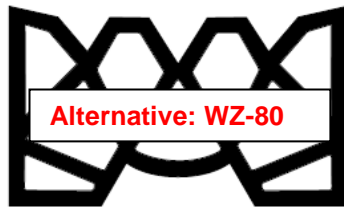

GC 350

NOTE

EF / GC / WF compression seals are now superseded by Granor FERMASEAL and WIZFLEX seals.

EF / GC / WF seals are still available by special order and “like-for-like” seal replacement outcomes.

For new designs please specify FERMASEAL or WIZFLEX seals.

Suggested Substitute	Seal Part No.	Joint Opening Gap (mm)			Typical Gap Width for Installation (mm)	Typical Groove Depth "D"
		Seal Minimum	Seal Maximum	Total Seal Movement Capacity		
16-203	EF-1250	11	25	14	16	40
16-204	EF-1750	14	38	24	22	45
16-205	EF-2000	16	41	25	25	51
WZ-50	GC-250	20	52	32	34	65
WZ-60	GC-300	22	62	40	42	68
WZ-80	GC-350	33	79	46	60	80
WZ-80	WF-400	32	86	54	55	70

Installation Overview

Correct installation is achieved by part compression of the seal together with the use of a lubricant/adhesive to aid installation. Installation is typically into either a concrete recess or between armoured faces. A formed/cut ledge or flat steel retainer bars are often specified to prevent the seal from being pushed too deep during installation.

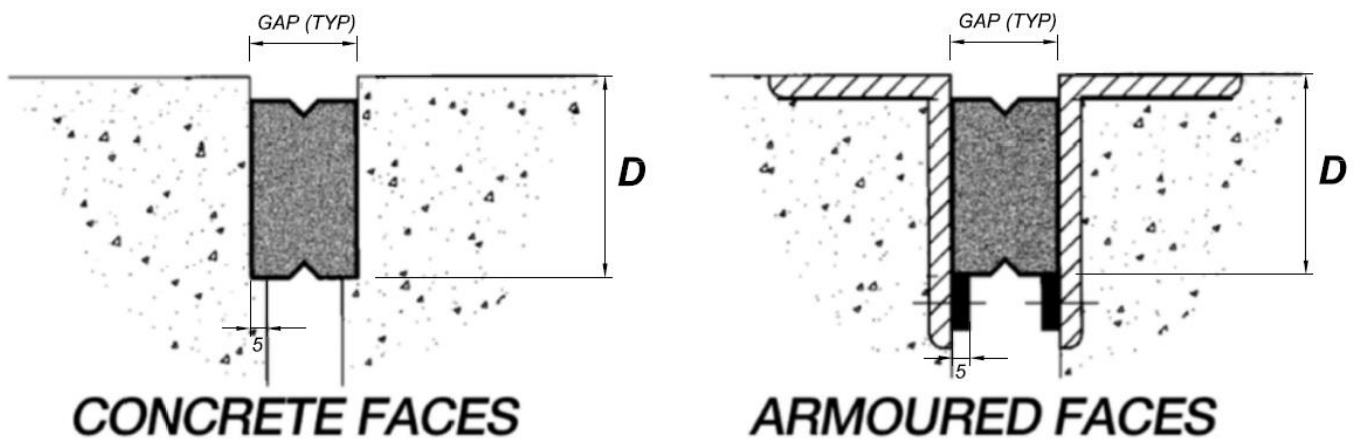

If installing into a concrete blockout, then the shape of the blockout is important in that the profile must be of correct depth, parallel in plan with sides parallel, and vertical. Concrete must be sound and free from loose lattice, spalling, cavities and projections that may affect the performance of the seal. As sharp edges at top of blockout can damage the seal during installation, it is desirable to chamfer 5mm x 45 deg.

If into steel armoured nosing/edging, then correct casting in to achieve a parallel gap width, vertical, and parallel sides, with top edge set at correct elevation to the trafficked surface, is important. Design of retention ligatures should be in accordance with relevant standards for the type of structure. In order to avoid damage to the seal during installation, all weld splatter and galvanising dags must be removed.

Care must be exercised to ensure that in service the compression seal is never over compressed and never exceeds its designed retained pre-compression requirement at maximum joint opening. Installation into correctly preformed nosing's of concrete or steel armoured can be quite rapid for experienced crews.

Installation Tools

For larger compression seals Granor® has proprietary installation tools available - making the installation process quicker and comparatively simple. For the small size seals, a pogo stick is typically used. For larger seals, the use of the 'clamp' tool is recommended in conjunction with the pogo stick.

Both can be hired from Granor.

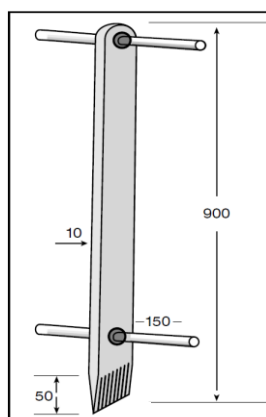

Lubricant / Adhesive

A moisture curing polyurethane base lubricant-adhesive is supplied with the seals to both aid installation and to provide a better more consistent sealing effect. This is applied by brush to both sides of the AUSFLEX® Seal, and both sides of the expansion gap immediately prior to inserting the compression seal. At all times, wear gloves and other appropriate PPE.

Installation Steps

- 1) Refer to the expansion joint dimension table - ensure seal selected is correct for movement expected, and joint is constructed correctly exactly as detailed on project drawings. Report any variation before proceeding.
- 2) Concrete interfaces shall be closely inspected for any defects, eg; spalls, honey combing, cracks, straightness etc. and all defects corrected. Epoxy mortar as approved by the Engineer should be used to correct any defects.
- 3) Steel or concrete interfaces shall be thoroughly cleaned, preferably by grit blasting or abrasive disc. All dust etc. removed by clean, dry compressed air jet. Irregularities shall be ground off, and faces finished true, flat, straight and parallel.
- 4) Surfaces, particularly the Compression Seal, to be bonded shall be wiped clean with an industrial strength solvent, eg; Acetone, xylene, toluol, or similar immediately prior to commencing installation, and allowed to dry.
- 5) The lubricant-adhesive supplied shall be applied to dry, dustless, cleaned joint interfaces and to the sides of the seal, typically one to two metres in front of the inserting process of the seal into the joint. It shall be brushed on uniformly to provide a liberal even coating to both interfaces of the joint gap, and the seal.
- 6) As the seal is inserted, it should be pressed down with the seal insertion tool (Pogo Stick) so that it is at the required distance below the surface. Typically this may be when the seal rests on the ledge or flat retainer bars which are often specified with these type of seals.

Note 1. – During installation of the seal it must not be stretched or compressed longitudinally – hold seal simply taut and straight.

Note 2. – By laying the seal out the day before installation will be assisted by removing any bends or kinks introduced during shipping.

Note 3. – At all times wear safety gear, particularly gloves.

Profiling to suit Kerb / Gutter

This diagram illustrates the process to 'profile' compression seals to suit a kerb or gutter profile. Care must be exercised not to cut or damage the top membrane of the seal.

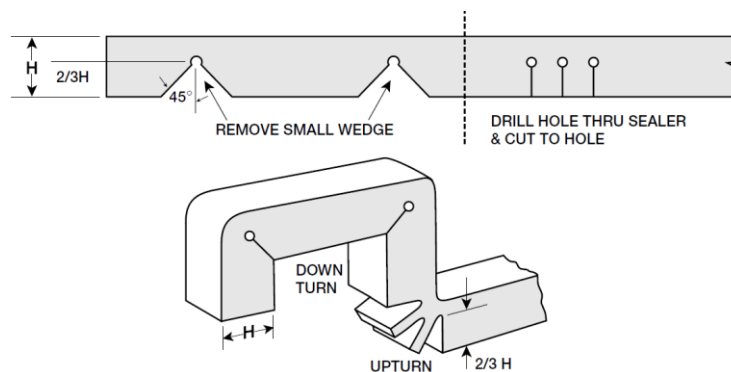

KERB DOWN TURN PROCEDURE

- 1) Locate the holes and drill through as shown. Do not cut into top membrane of seal.
- 2) Using a sharp long bladed knife, cut a triangular section from the lower section of seal towards the outer edge of the hole(s) as illustrated.
- 3) Bend seal to the desired profile.

KERB UPTURN PROCEDURE

- 1) Position the three holes as illustrated and drill through – ensure they will not penetrate into the top membrane of seal.
- 2) Using a sharp knife, cut three lines - normal to the underside of seal - towards the centre of each hole.
- 3) Bend the seal to the desired profile.