

STRUCTURAL BEARINGS

GRANOR® FLUOROGOLD® SLIDE BEARINGS – SERIES FSB

GRANOR® Fluorogold® Slide Bearings are simple in concept, easy to fabricate, and easily adaptable for installation in accordance with customer’s requirements.

Fluorogold bearings are essentially free float point load slide bearings without a vertical rotation capacity. They are suitable for a range of relatively light loads and movement capacities.

APPLICATIONS

- > Pipe Supports
- > Light Steel Structures
- > LNG Facilities
- > Chemical Refineries
- > Desalination Plants
- > Tank Top Bearings

DESIGN

The total bearing assembly is made up of two Fluorogold elements with differing plan size sliding against each other. In all cases, the larger of the two Fluorogold elements is positioned on the top.

The dimensional difference between the upper layer and the lower layer represents the slide movement capacity.

The recommended maximum allowable design load for Granor® Fluorogold® Slide Bearings is 10MPa.

This type of bearings has frictional values ranging from approximately 6% at a compressive load of 5MPa. to a 4% coefficient of friction at 10MPa. A coefficient of friction of 10% is recommended for design calculations.

There are many different configurations available for this type of slide bearing with no standard plan sizes. Typically, a welding lip is provided for tack welding to steel structures and / or this lip permits the use of countersunk stainless steel screws for direct attachment to the structure.

Fluorogold® slide bearings are not designed to handle any non-uniform (i.e. induced rotation) loading conditions. Where a rotational capacity is required then a “DBA” type bearing (cast-in-situ) or “BFP” type bearing (bolt on) should be used instead.

MATERIALS

GRANOR® Fluorogold® Slide Bearings are made using genuine Fluorogold material with full certification. The Fluorogold material is factory bonded to thin backing plates either 316L stainless steel or carbon steel.

DIMENSIONS

The following dimensions should to be shown on project drawings when specifying Fluorogold bearings:

**PLAN VIEW – TOP ELEMENT
(VIEW FROM UNDERSIDE)**

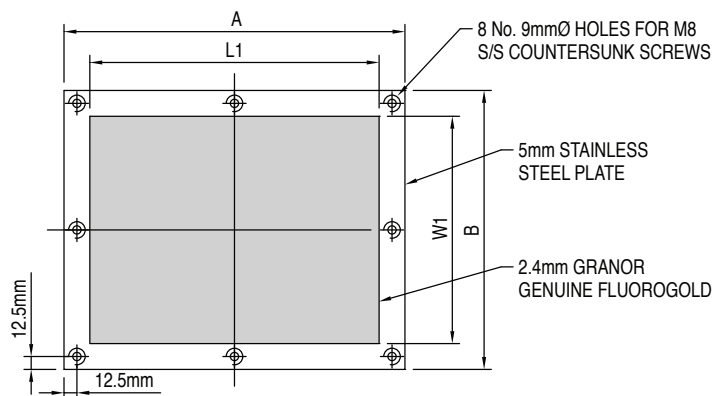

SIDE VIEW



PLAN VIEW – BOTTOM ELEMENT

