

## EXPANSION JOINTS – Large Movements

### GRANOR® / ETIC Aluminium Finger Joints - “Series EJ”



The Granor ETIC® EJ series “Saw Tooth” Finger joints are robust watertight Bridge deck expansion joints that accommodate larger movements up to 300mm total capacity.

These joints should be adopted where the structure gap will open beyond 85mm ULS, in which case the use of a ‘stripseal’ type single seal element joint will transgress the maximum 85mm open gap criterion nominated in AS5100.4

The EJ series joints are available in two differing movement series.

The EJ-80, EJ-110 and EJ-160 model joints utilise a single concertina central sealing gland and synonymous with the part number nomenclature are capable of 80mm, 110mm and 160mm of total movement respectively.

The second series of EJ joints, the EJ-200, EJ-250 and EJ-300, utilise a dual concertina seal arrangement and accommodate total movements of 200mm, 250mm and 300mm respectively.

Type	A*		B		S*		J*		C	D	E	F	H	L
	min.	max.	min.	max.	min.	max.	min.	max.						
EJ80	80	160	220	300	20	100	0	80	66	59	67	200	260	250
EJ110	110	220	260	370	30	140	0	110	73	59	84	250	260	300
EJ160	160	320	356	516	40	200	0	160	85	59	120	250	310	350

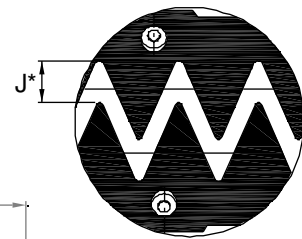

PLAN VIEW FINGER GAP

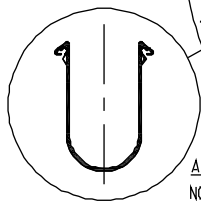
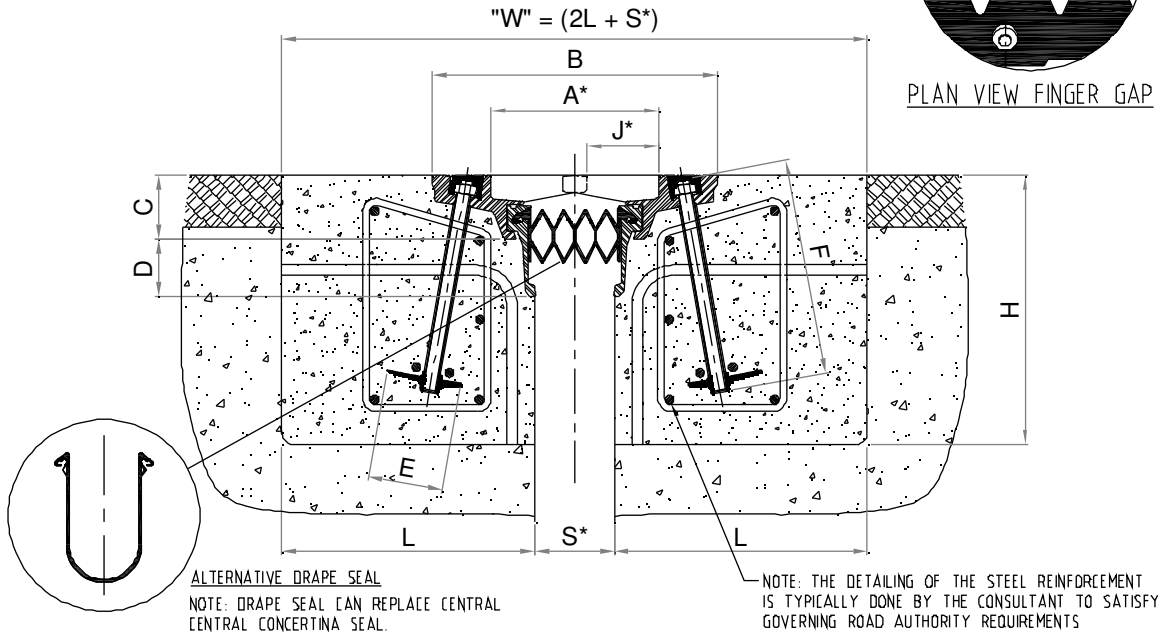

ALTERNATIVE DRAPE SEAL  
NOTE: DRAPE SEAL CAN REPLACE CENTRAL CENTERTINA SEAL.

### GRANOR ETIC EJ EXPANSION JOINT SYSTEM EJ80 - EJ160

Type	A*		B		S*		J*		C	D	E	F	H	L
	min.	max.	min.	max.	min.	max.	min.	max.						
EJ200	200	400	420	620	50	250	0	200	113	59	120	250	310	350
EJ250	250	500	510	760	50	300	0	250	120	59	120	300	360	400
EJ300	300	600	600	900	50	350	0	300	133	59	120	300	360	450

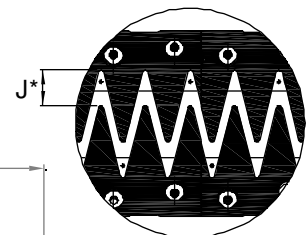

PLAN VIEW FINGER GAP

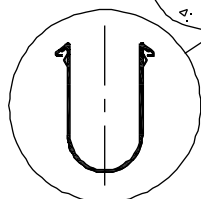
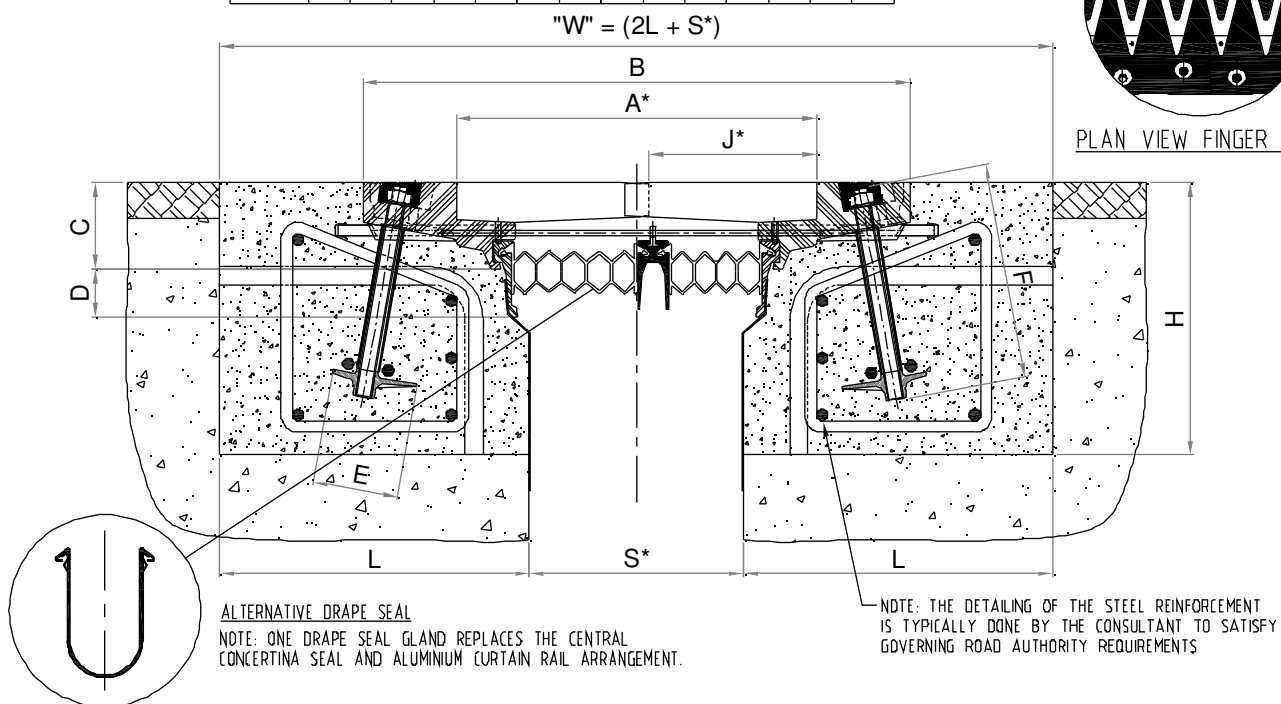

ALTERNATIVE DRAPE SEAL  
NOTE: ONE DRAPE SEAL GLAND REPLACES THE CENTRAL CENTERTINA SEAL AND ALUMINIUM CURTAIN RAIL ARRANGEMENT.

### GRANOR ETIC EJ EXPANSION JOINT SYSTEM EJ200 - EJ300

**A\* (min.)** - Is when the fingers are fully closed up. **A\* (max.)** - Is when the fingers are fully open.

**J\*** - Is the critical metal to metal gap between the ends of respective assembled joint components, at the time of installation, as determined by the engineer after consideration of future opening and closing of the fingers.

**S\* (min.)** - Is the minimum acceptable gap when fingers are fully closed up.

**S\* (max.)** - Is the minimum acceptable gap when fingers are fully open.

## Design Features

The EJ series joints consist of three main elements:

### Cast aluminium saw tooth elements

These 1 metre long elements have a 'saw tooth' shaped profile in plan, which interlock with the opposing element, thereby providing a smooth unencumbered transition over the large underside structure gap.

### Elastomeric sealing profile

This sealing element is a concertina shaped multiple chamber of robust EPDM extrusion, which interlocks into a supporting aluminium retainer that itself locates into the cast aluminium saw tooth elements. The larger movement versions EJ-200 to EJ-300 utilise a dual seal system, supported by stainless steel curtain rods that locate into the cast aluminium elements on each side of the gap.

An alternative draped membrane "trough" shaped flexible PVC seal is also available for detailing on all 6 models in the range.

### Tensioned – High tensile fixings

The metallic cast aluminium joint elements are strongly fixed to the structure by way of tensioned tie-bolts on each side. This provides for a superior retention mode whereby fixings undergo minimal load fluctuation and do not suffer from fatigue based failure.

### Skew Orientation

The EJ-80, EJ-110 and EJ-160 joints are capable of accommodating skew orientations without compromise of movement capacity for skews up to 23°. For larger skew orientations these models can still be used, but a redundancy of movement range is required. Please consult Granor staff for full advice on such reductions in movement capacity relative to skew orientations beyond 23°

The larger capacity EJ-200, EJ-250 and EJ-300 joints have more 'pointed' fingers and thus are very limited in their ability to accommodating skew orientations. Consult with Granor Staff for advice on such limitations. Should you have a large movement case with associated larger skew orientation, the Granor Steel Finger joints series SFEJ should be specified.

### Installation

The EJ series expansion joints are cast into appropriately formed blockouts, per the minimum dimensions in the above tabulations.

Void former by way of polystyrene or formwork that can be removed from underside the joint is placed in the expansion joint gap to the appropriate gap set "S" at the time of installation. It should be noted that the important set dimension at time of installation is the gap set "J" being the gap at the top of the joint system between the fingers. The underside gap set "S" is a function and a result of the establishment of gap set "J".

The total system is preassembled above the blockout and suspended with purpose steel suspension arms and brackets (Granor Installation Kit) to the correct level and "J" gap set width. The system's fixings are placed such that they locate perfectly normal to underside plane of the joint system and the required reinforcement placed and tied. The top of the joint is protected from concrete slurry ingress and the blockout infill concrete is placed with thorough vibration practices. The suspension brackets are loosened once the concrete has solidified in order to allow structure movement to occur without pulling and shifting the joint system prior to full concrete cure.

Upon achievement of 30Mpa concrete strength the joint fixings are tensioned to the advised torque setting and re-torqued 24 hours latter, after which a bituminous compound is placed in the bolt well recesses. The joint is now ready for full trafficking.