

Type	A*		B		S*		J*		C	D	E	F	H	L
	min.	max.	min.	max.	min.	max.	min.	max.					min.	
EJ80	80	160	220	300	20	100	0	80	66	59	67	200	260	250
EJ110	110	220	260	370	30	140	0	110	73	59	84	250	260	300
EJ160	160	320	356	516	40	200	0	160	85	59	120	250	310	350

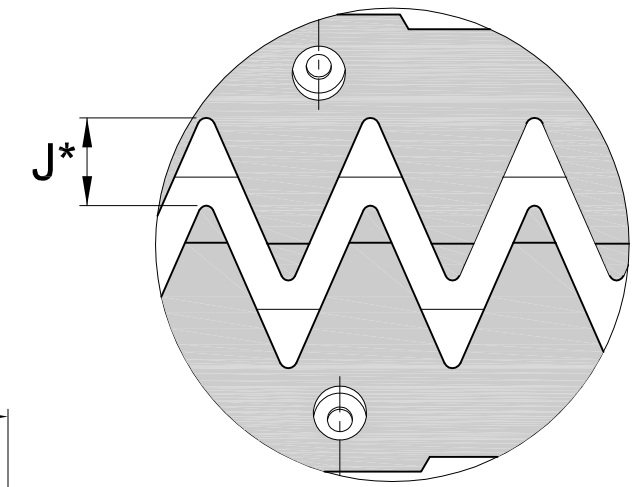

PLAN VIEW FINGER GAP

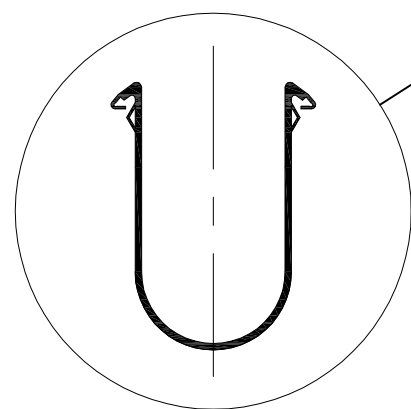
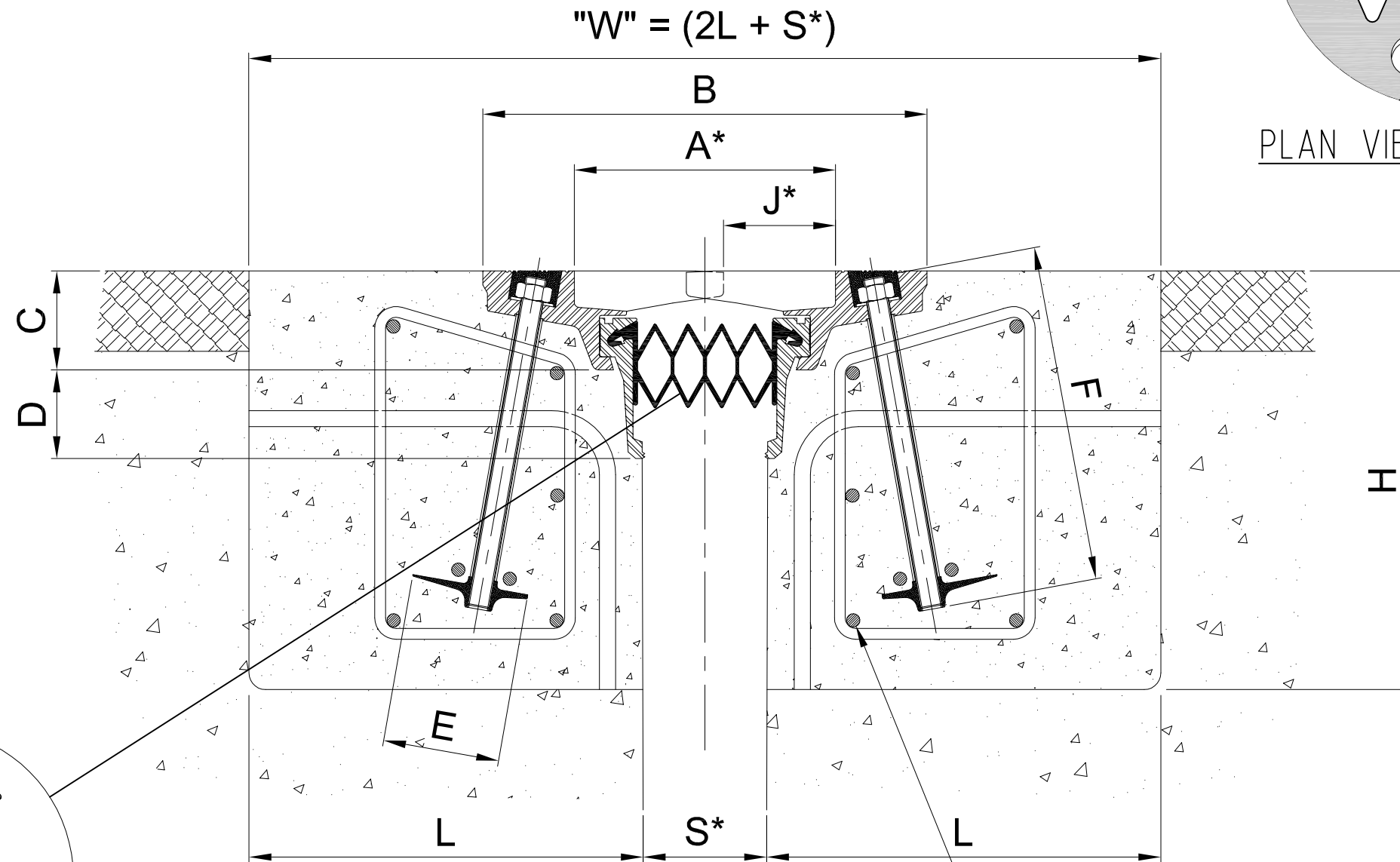

ALTERNATIVE DRAPE SEAL

NOTE: DRAPE SEAL CAN REPLACE CENTRAL CENTRAL CONCERTINA SEAL.

GRANOR ETIC EJ EXPANSION JOINT SYSTEM

SECTION - FIGURE -.-.-(-)

- A* (min.) - Is when the fingers are fully closed up. A* (max.) - Is when the fingers are fully open.
- J* - Is the critical metal to metal gap between the ends of respective assembled joint components, at the time of installation, as determined by the engineer after consideration of future opening and closing of the fingers.
- S* (min.) - Is the minimum acceptable gap when fingers are fully closed up.
- S* (max.) - Is the minimum acceptable gap when fingers are fully open.